

Deterministic Design of Machines using Error Budget Methods

In the process of designing a new machine, the designer typically starts with ideas, sketches, quick calculations (at least first order estimates) of feasibility, and then gets ready to start investigating ideas in more detail. However, before investing a lot of time in solid models and finite element analysis, it can be helpful to more deeply consider in a deterministic way the performance of different concepts either wholly or partially (e.g., a particular axis). The technique of first order error apportionment among axes and components followed by more detailed error budgeting can be helpful to investigate design ideas and options.

First step: Error apportionment

The designer needs to have an idea of the number of axes needed to accomplish the task, and the overall accuracy (or repeatability) of the machine. Assuming no particular axis should “work harder” than another to deliver performance, the total allowable error can be apportioned amongst axes and components within axes. This can be done with the spreadsheet *Axis_error_apportionment_estimator.xls*

Axis error apportionment estimator.xls								
To apportion errors between types and axes. By Alex Slocum, last modified AHS 2016.02.22 for 2.70 PUPs 3								
Enter numbers in BOLD , Results in RED								
Number of axes, N	3							
Total allowable error, dtot (microns)	100							
Apportion of error within each axis (amount allocated to each of X, Y, Z directions) to be determined by sensitive directions								
				Bearings (fb)	Structure (fs)	Actuator (fa)	Sensor (fs)	Cables (fc)
Source of error	Factor (f)	Apportion of error (dtot/f)	Apportion of error per axis	1	0.5	0.2	0.2	0.1
Based on linear sum of errors								
Geometric, fg	1	40.000	13.333	6.667	3.333	1.333	1.333	0.667
Thermal, ft	0.25	10.000	3.333	1.667	0.833	0.333	0.333	0.167
Load-induced (deflection), fl	1	40.000	13.333	6.667	3.333	1.333	1.333	0.667
Process, fp	0.25	10.000	3.333	1.667	0.833	0.333	0.333	0.167
Based on root square sum of errors								
Geometric, fg	1	68.599	39.606	34.214	17.107	6.843	6.843	3.421
Thermal, ft	0.25	17.150	9.901	8.554	4.277	1.711	1.711	0.855
Load-induced (deflection), fl	1	68.599	39.606	34.214	17.107	6.843	6.843	3.421
Process, fp	0.25	17.150	9.901	8.554	4.277	1.711	1.711	0.855
Average (expected case) of linear and RSS								
Geometric, fg	1	54.300	26.470	20.440	10.220	4.088	4.088	2.044
Thermal, ft	0.25	13.575	6.617	5.110	2.555	1.022	1.022	0.511
Load-induced (deflection), fl	1	54.300	26.470	20.440	10.220	4.088	4.088	2.044
Process, fp	0.25	13.575	6.617	5.110	2.555	1.022	1.022	0.511

We now have an idea of the dimensional performance requirements (e.g., accuracy or repeatability) for the primary elements in the system. When very high performance is required where it seems like we will have to work very hard to meet the requirements, The next step is to assign coordinate systems and then to estimate the error motions in the elements and stiffnesses of connections (e.g., bolted joints, bearing elements) between coordinate systems and the compliance of structural elements.

Second step: Concept Development with the aid of an Error Budget

An error budget can be used to first assess just geometric errors, and the designer can assume if geometric errors can be managed according to limits allocated in the error apportionment phase, then the load-induced errors could also be dealt with by appropriate component sizing. The designer can then proceed using simple calculations to size elements to solid model the concept, and then use FEA to predict deflections and make sure they are within the limits set by the error apportionment phase. This requires an iterative process and some hope that when the entire machine is assembled all will be well.

A more deterministic approach is to do a second round of error budgeting where applied loads and the stiffness of joints and bearings and compliance of structural elements are added to the model. This discrete element model effectively considers the net effect of geometric errors and load induced deflections to predict overall machine performance. Being spreadsheet based, the designer can rapidly spot trends and adjust member and bearing sizes (stiffness) accordingly to converge on a workable design. THEN the design can be solid modeled and checked with FEA against the and the model considers

To illustrate the latter approach, this document will guide users through using error apportionment and error budget spreadsheets by applying them to a bridge style machine intended for use as a wood router in a home shop.

Where to start?

A designer often starts at the tool and works backwards to the base. The rationale is that the designer should have an idea of the stiffest tool that will be used and the power and speed of the spindle.

Figure 1 shows some stick figure concepts for the to-be-designed router. Keeping early stage designs in the hand-drawn phase enables the designer to spend more time with young family members creating concepts in Crayon, as shown in Figure 2, as well as preventing business overlords from assuming the design is finished and so they start taking orders... It also helps the designer to relax and more freely think of design options... Drawing animals and fun shapes within a design helps keep young helpers happily engaged and promotes free-spirited creative thought in the designer. It is like a dither signal that is sometimes used to help a servo overcome friction.

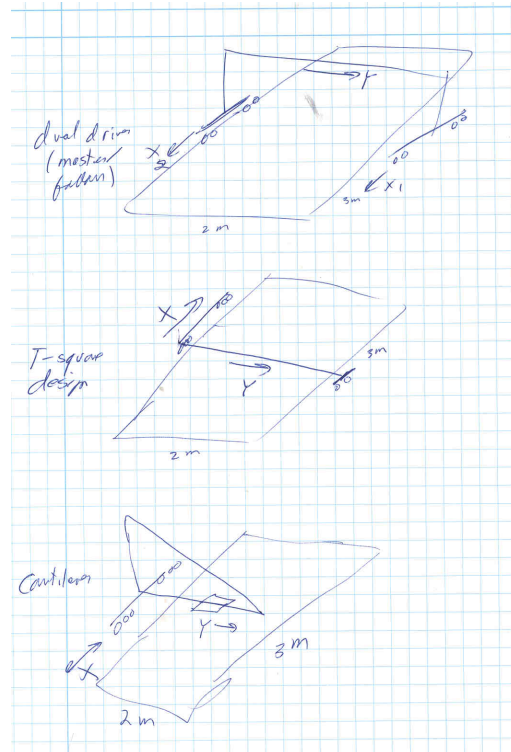

Figure 1: Early Stick Figure concepts for routers as motivated by consideration of Functional Requirements, Design Parameters, Analysis, References, Risks, & Countermeasures (FRDPARRC¹)



Figure 2: Crayons, big sheets of paper, blocks..., and a young helper do wonders for creativity and happiness of all involved.

¹ **Big Awesome** (©) Design acronym (created to make fun of TMS-TLAs). See for example Graham, M, Slocum, A, Moreno Sanchez R., "Teaching high school students and college freshman product development by Deterministic Design with PREP", ASME Journal of Mechanical Design (Special Issue on Design Engineering Education), July 2007, Vol. 129, pp 677-681.

Given that a full sheet of plywood is ideally to be cut, a bridge style machine is selected as the approach to first consider. Even in the stick figure phase, it is a good idea to start to think about coordinate systems that will represent the major elements of the machine. The best way to assign coordinate systems is to think of the centers of stiffness of the system, particularly where the bearings attach, which are simply represented in the stick figure. Start simple and think in terms of cantilever and simply supported beams, so you might have more coordinate systems than moving degrees of freedom. The bridge concept path that has been decided upon can be envisioned as being modeled with 7 Coordinate Systems:

1. Tool in Tool Holder
2. Spindle
3. Z axis
4. Y axis
5. Vertical Riser
6. X axis
7. Cutting point on workpiece

As discussed in more detail below, every Coordinate System N has an origin to where it will attach to the next Coordinate System N+1, and a *Point Of Interest* (POI) to which the previous Coordinate System (N-1) is attached.

Figure 3 shows a first pass isometric view, still hand-drawn to prevent too early lock-in to design details as can be the case when solid models are too early created in the design phase.

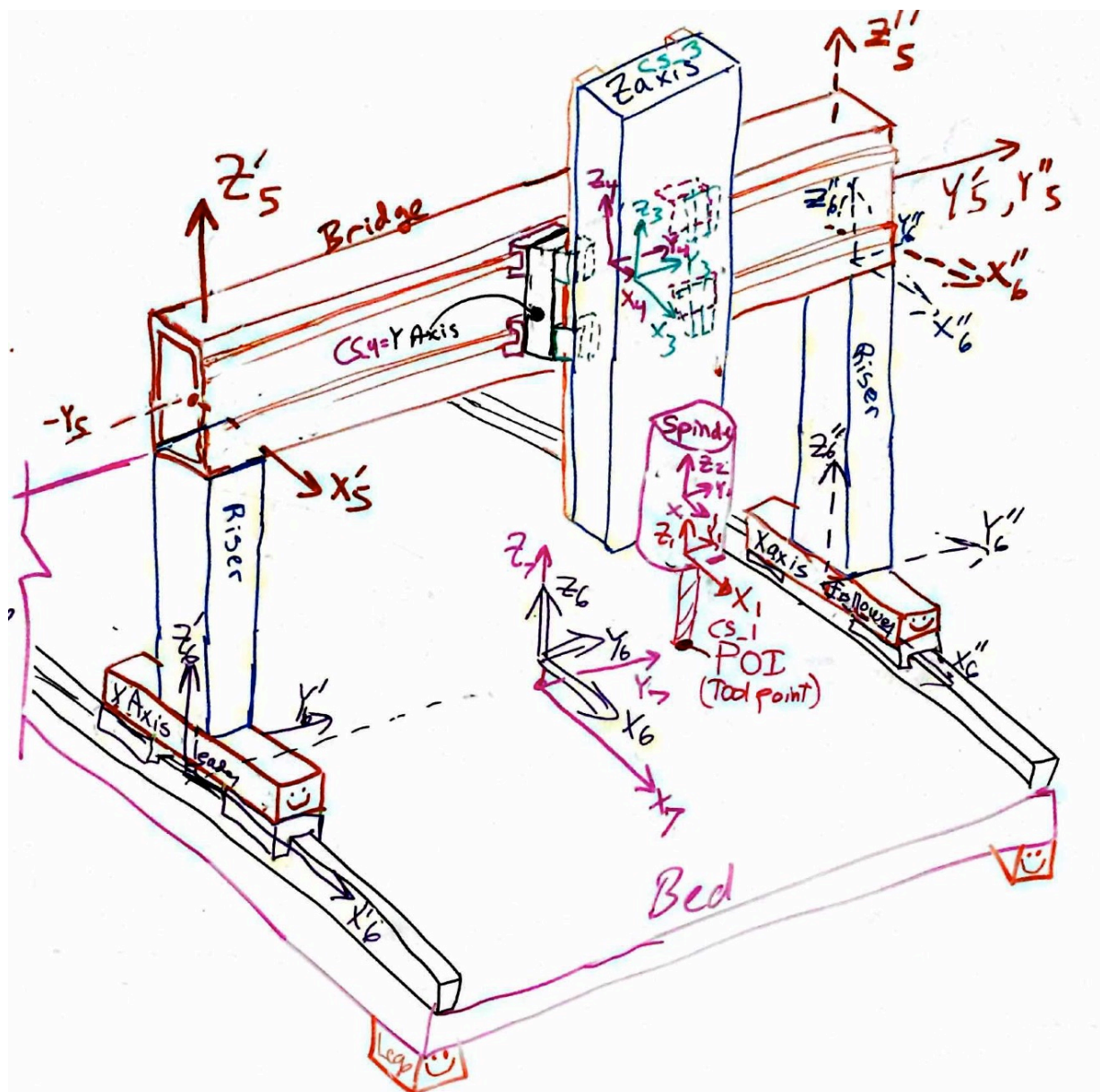

Figure 3: Whiteboard sketched bridge machine concepts for a router (created at white board based on inspiration from early sketches created as in Figure 2).²

As the bridge structure in Figure 3 was sketched, the designer started thinking about how it might be built and thus also modeled: where should coordinate systems be placed? Indeed, many corrections and adjustments were rapidly made along the way using an eraser and markers. A big DO NOT ERASE note ensured that the design could remain for several days so it could mature with the help of peer review by colleagues who wandered into the office were very valuable. Sticky notes were sometimes added and used to capture ideas that

² Can you find all the smiley faces? Ideally there would also be small wild animals hidden within. Staying a little silly helps keep the designer free thinking so as to not get too enamored, and hence resistant to change, with their own design too early.

were not quite ready to replace existing lines. The process was catalyzed and lubricated by lunches and coffee breaks. Throughout, the process enabled thinking about coordinate systems that represent motion axes and connections between major structural elements.

The entire process shows that it is good to use a whiteboard for early development. This “fuzziness” is an important part of the creative phase. Analysis (as in equations and also critical thinking about obtaining components, manufacturing...) can be thought of as a lens that helps bring a design into focus.

A note about assigning coordinate systems, which will be discussed in more detail below. Every Coordinate System (CS) has a Point Of Interest (POI) and a Point Of Attachment (POA), which by convention here is at the origin of the CS. Accordingly, one CS's origin (POA) is located at another's POI. Meanwhile, errors in machines are dominated by systematic errors (e.g., axes are not bolted together exactly square, or repeatable straightness error in an axis), random errors (e.g., bearing noise), and deflections. The latter are due to limited stiffness at joints and bearings and compliance in structures.

It is thus logical to follow the structural loop of the machine, which traces the path of forces through the machine from toolpoint back through the machine and up into the workpiece where the tool is acting, and place a CS's POA at a connection between major elements. Hence each CS's POI will be collocated with the next CS's origin which is at a connection between major elements... The stiffness of the connection between coordinate systems can thus be represented by springs between one CS's POA and its adjoining CS's POI. Within a coordinate system, the compliance of the structure that connects the POA to the POI can then be represented by a full (6x6) compliance matrix as discussed below. Figuratively the sequence is shown in Figure 4.

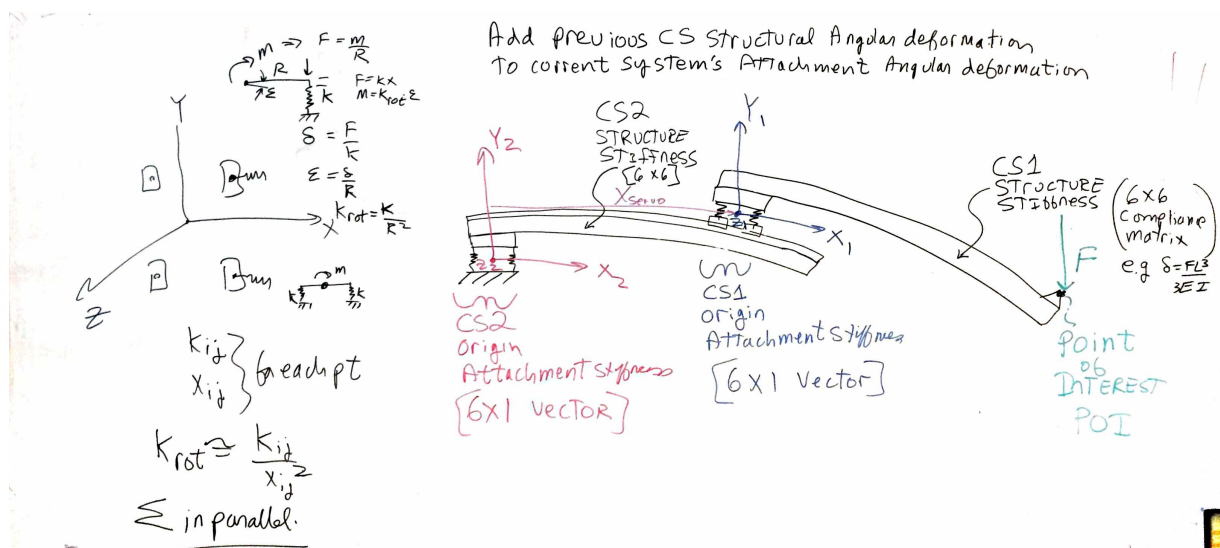

Figure 4: Modeling a machine as a sequence of compliant beams and discrete spring connections.

Once the overall concept has mostly congealed, different views, close ups and cross sections of regions can be sketched to help the designer better understand as shown for example in Figures 5 and 6. One method of design synthesis is to start at the tool tip, because that's where the action is, and keeping in mind the forces and accuracy desired, create elements along the structural loop to enable the desired motions to occur, and conceptually size them in accordance with their distance from the tool point. This is the phase where one moves from a stick figure to at least quasi reality ☺.

Following this logic, consider the machine in Figure 3 and the cross section in Figure 5. CS_1's origin (POA) is located at the center of the collet that holds the tool. The POI is the tool tip and the compliance of the tool (1/stiffness) can be easily determined. The stiffness of the tool held in the collet and the collet in the tapered receiver of the spindle shaft would be modeled as a set of linear and rotary springs where resultant forces and moments on the CS's origin cause linear and angular displacements respectively. This might require experimentation or a literature search as surely this has been tested before.

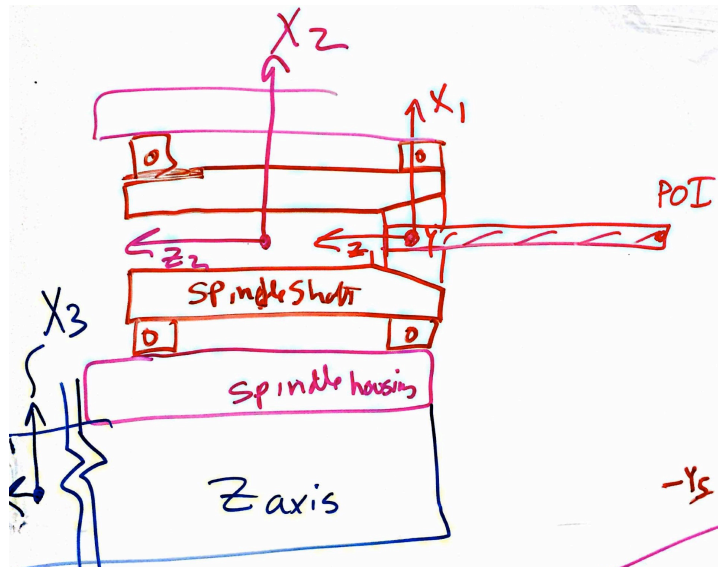

Figure 5: Whiteboard sketched cross section of the tool, collet, and spindle on the end of the Z-axis structure. Note Y axis is positive into the page so a positive X direction force would cause a negative rotation about the Y axis.

CS_2 needs to be able to model the stiffness of the spindle bearings as well as the spindle shaft. If it were located at one bearing or the other, the angular error created by the resultant moment from the force at the tool point may not be completely captured. Yet the spindle shaft may also be a significant source of compliance. The joint between the spindle housing and end of the Z-Axis structure is likely to be far more rigid than the spindle bearings, and hence we will focus our efforts on the spindle bearings.

Placing CS_2 at the center of the spindle shaft, and modeling its attachment stiffness to the POI of CS_3 (the end of the Z-Axis) as the linear and angular (pitch and yaw) stiffness of the spindle bearings and housing will accurately reflect the effect spindle bearing deflections have on the motion of the tool tip.

But what of the deflections of the spindle shaft, the compliant structure connecting CS_2's POA to its POI which is the origin of CS_1? The spindle shaft conservatively looks like a simply supported beam unless it is a slow speed spindle with a significant set of back to back mounted rolling element bearings at its front. In either case, linear deflection of the simply supported beam is not significant because CS_1 is considered located at a support point (the front spindle bearing) but angular deflections are important: The slope deflection of the spindle shaft at the POI directly affects angular deflection and hence Abbe error of the tool tip. Since the relative position of CS_2 and CS_1 does not change we can locate CS_2 at the center of the spindle shaft, and model the compliant beam that connects CS_2's POA to its POI as a simply supported beam whose length is that of the entire spindle shaft.

Moving on to the rest of the system, consider Figure 3 and Figure 6 which shows a side view of the machine, where it should be clear that CS_3's origin is at the Center of Stiffness (COS) of the Z bearings (e.g., two linear guide (profile rail) cartridges (generically called *bearing blocks*) on each of two profile rails). The stiffness of these bearings with the local structure will dominate the attachment stiffness of the CS_3's POA to CS_4's POI. The compliance between CS_3's POA and POI will be that of the Z-Axis structure, sometimes called the *ram*, which can be modeled as a cantilever beam, whose length changes in accordance with the position of the spindle, which is controlled by the Z-Axis actuator. That Z-Axis actuator will thus be the Z-Axis compliance value in the {6x6} compliance matrix, where the other entries are due to those of a cantilever beam.

Note in this design the Z-Axis bearing blocks are attached to a chunky structure to which the Y-Axis bearing blocks are also attached. In this case CS_3's POA (origin) is attached to CS_4's POI and there really is no compliant structure between the two. Hence the compliance matrix for CS_4's "structure" would just be the null matrix of zeros³.

³ In a spreadsheet this is easier to do, because old values can be deleted and the default value is "0" in subsequent calculations that reference the cells. Else if the analysis was based on using a stiffness matrix (instead of the compliance matrix) the user would have to delete values and enter 1E12 or some such super huge value

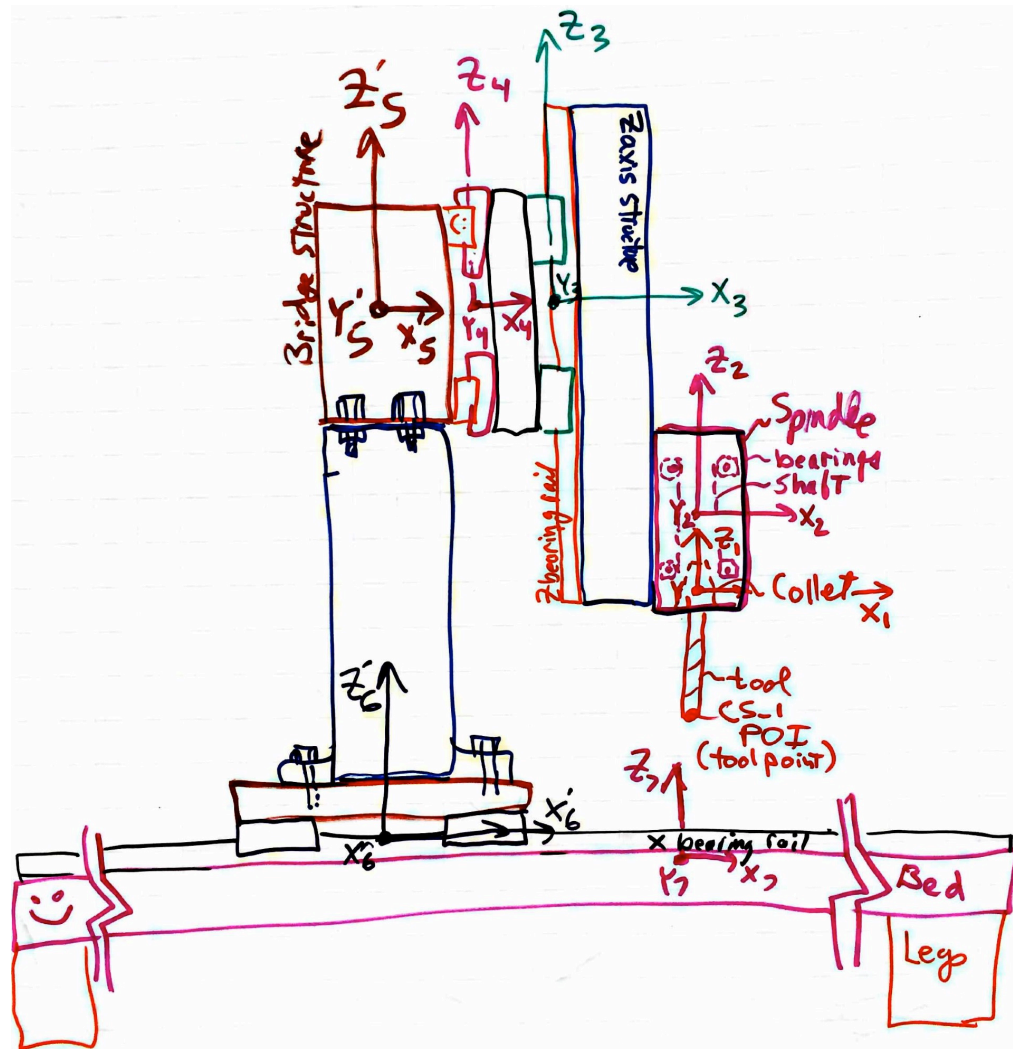

Figure 6: Whiteboard sketched side view of the machine.

The bridge of the machine represents a closed structural loop, whereas the matrix methods that are to be used to analyze errors (Homogeneous Transfer Matrices, HTMs) is a serial based approach. The solution to this quandary is to visualize how the machine deforms and consider the philosophy of POA springs and the compliance matrix that represents the structure between the POA and the POI.

With this in mind, place the origin of CS_5 at the top of one of the risers that connect the X-Axis bearings to the bridge beam. The bridge beam is considered a simply supported beam, when the Y, Z axis assembly is all the way to the right and thus far away from the origin of CS_5 one might think this represents a HUGE moment that will cause an inordinately (and inaccurate) Abbe error. However, note in Figure 3 how the axes directions have been donated as CS_5' and CS_5'' (e.g., Z'_5 and Z''_5). This indicates that the attachment points are far apart. Given that they are each very stiff, the moment stiffness of two linear springs representing the attachment points, which are spaced far apart, is also HUGE (see the linear springs spaced apart yielding rotational spring analysis method on the left side of Figure 4)

and thus the resulting inaccuracy of an Abbe error caused by angular deflection of the coordinate system is very small, and in the worst case just adds to the conservative nature of the model.

The simply supported beam model of the bridge is used to determine the compliance matrix for the structure between CS_5's POA and its POI (which is also CS_4's POA). As the Y-Axis servo moves the Y, Z axis assembly from left to right, the slope will change from negative to zero (when its in the middle) and back to positive. Hence the Abbe error at the tool tip will be accurately accounted for.

The same philosophy is used for CS_6 which models the X-Axis. Note that the compliance matrix for the structure between CS_6's POA and POI is a little more interesting because of the two risers. This just means that the bending stiffnesses are the combined stiffnesses of the two riser elements, but the torsional stiffness about the Z axis is based on the bending stiffness of the risers spaced apart (analogous to the method shown on the left side of Figure 4).

Note that the effective center of CS_6 is thus at the center of the table. However, in terms of the spreadsheet model (and coordinates entered) it will be kept at the center of stiffness of the left side X bearings. The final coordinate system is then placed on the workpiece on the table at the point where the tool will contact the work.

To model the effect of springs and compliances associated with CS_7 takes some thought experiments. This is essentially the same condition as with the bridge, where CS_4 (analogous here to CS_7) moved along the bridge and CS_5' and CS_5'' (analogous to CS_6' and CS_6'' here) were located at the ends of the bridge. Reciprocity!

The POA for CS_7 is thus modeled as the stiffness of the workpiece from where the tool contacts it to where it is attached to the bed (in most cases this should ideally be infinite with respect to the stiffness (1/compliance) of the tool). The compliance of CS_7 from its POA to its POI is the compliance of the machine frame and bed and is modeled as a simply supported structure. However, some finesse is required to apply the resultant forces and moments from CS_6 to the compliance matrix. The resultant forces and moments on the origin of CS_7 are applied to the compliance matrix to obtain the apparent deflections of the POI of CS_7.

The structural loop is thus complete and modeled. Figure 7 summarizes coordinate systems 1 through 7 and their origins (points of attachment) and points of interest. Such a table can be helpful for the designer when building the detailed error budget. Indeed, recording sketches made and freeform writing to record the thinking associated with placement of coordinate systems and modeling of stiffnesses and compliances can be invaluable to the designer and associates. The act of writing, knowing others will read, helps to hone thoughts and resolve quandaries. It also makes it easier for peer review to help identify and correct issues.

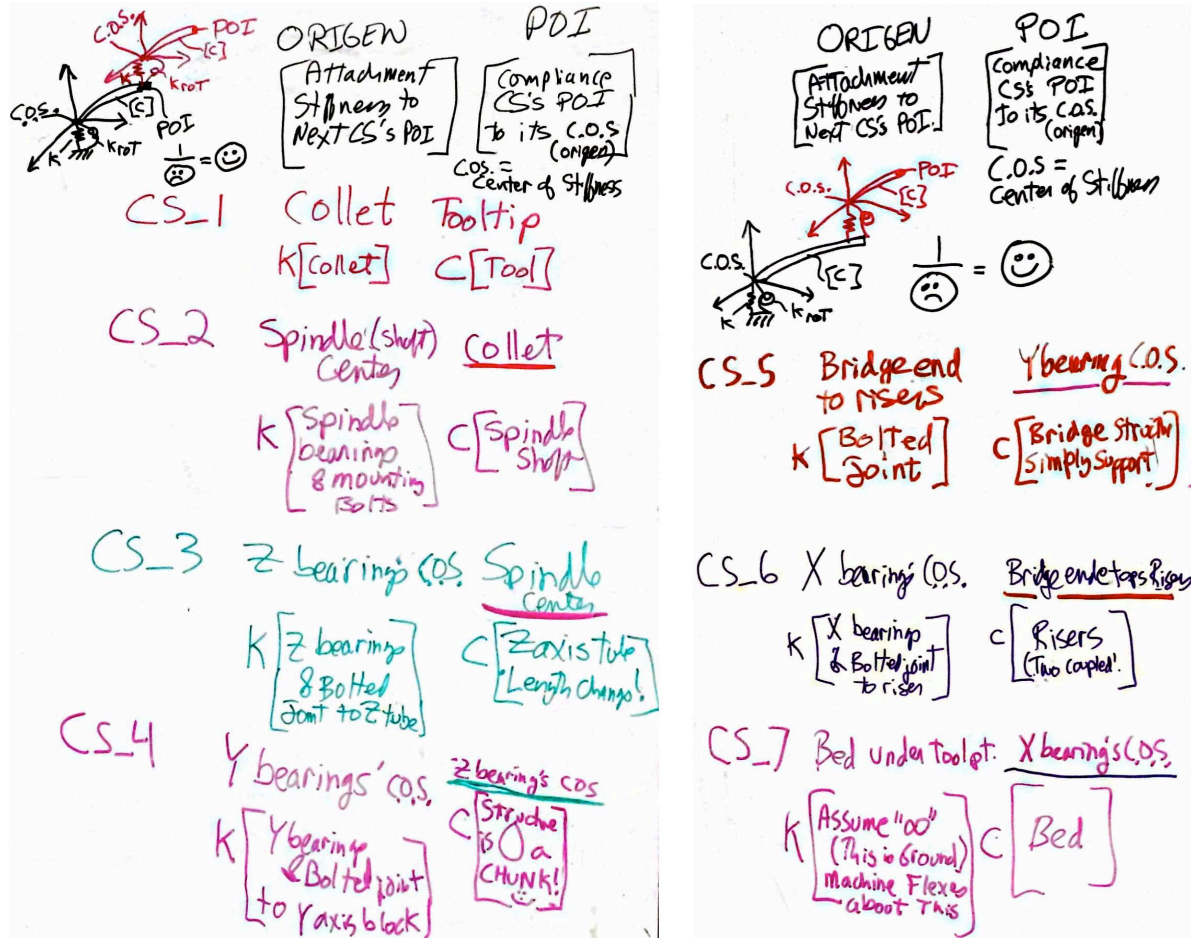

Figure 7: Summary of coordinate systems 1 through 7 and their origins (points of attachment) and points of interest.

“Stiffness” (Compliance) of elements between a CS’s POA and POI

In order to assign reasonable values to the distances between coordinate systems origins for the concept shown in Figure 3 so the error spreadsheet can be utilized, a sense of proportion of the size of the structural elements is needed.

First start with an estimate of the loads on the tool, and given the allowable error of structural elements (Figure 1), the stiffness required of each axis can be estimated. Given that some of the parameters are essentially a “guess” based on what may seem reasonable, the resulting stiffness guestimates should be treated as fuzzy estimates subject to change and barter as one idea or element is traded off for another. The tool tip is thus the point of interest. A spreadsheet is a good way for a designer to quantify initial guestimates, as shown for the router for example Figure 8.

Router_design_engineering			
created by Alex Slocum 2016.02.20			
Inputs in BLACK Outputs in RED			
Router power			
	HP	Name	3
	Watts	P	2237
Tool			
	diameter (mm)	Dt	25
	speed	http://www.rockler.com/how-to/router-bit-speed/	
	rpm		20000
	rad/sec	w	2094
	Torque (N-m)	T	1.068 ! =P/w
	Radial cut force (N)	Fc	85.5 ! =T/(Dt/2000)

Figure 8: Initial assessment of forces on the cutting tool.

Next from the first guess error apportionment shown in Figure 1, we see for the three-axis router we are designing here, each axis' structure is allocated 10 microns of error (deflection). This means that each axis must have a structural stiffness of about $85.5\text{N}/0.010\text{mm} = 8550\text{ N/mm}$.

Assuming for now the joints are much stiffer than any one beam, something we will have to pay careful attention to during the design phase. Given the bridge type structure of Figure 3, for 1.3 m travel (so as to cut a 48" wide sheet of plywood) the bridge would be at least 1.4m between the uprights. Remember, the stiffness (compliance) goes like L^3 so be frugal with adding space for what seems like ease of design or packaging. In order for a 1.4 m long simply supported beam to yield the a stiffness of 8550 N/mm in the middle of the beam, the equation for deflection of a simply supported beam loaded by a force in the middle is $FL^3/48EI$, a square aluminum cross section beam must have a moment of inertia of about $7E6\text{ mm}^4$. This seems large, but can be obtained with a standard stock extruded aluminum square tube 6in x 6in, x 1/8" wall, which would be a very efficient beam (high stiffness to weight).

To help build design intuition, its interesting to explore possibilities. Assume we were wanting to machine metal with higher precision than a simple router would provide and we wanted a stiffness in our simply supported beam of about 64 kN/mm (8X). This requires a square beam of about 200mm x 200mm x 12mm wall (stock US size is about 8in x 8in x 1/2" wall), or equivalently a 250mm x 250mm x 6mm wall thickness. Considering the beam is 1400mm long, the ratio of length to height of the latter is about 5.6. A 300mm x 300 x 5mm thick beam would have the same cross sectional area and be 40% stiffer! Think of Saint Venant for beams that have the same stiffness, the length/cross section dimension proportions are 7, 5.6, and 4.7, and the relative areas (weights) are 1.00, 0.65, and 0.39 respectively.

How to choose? The bigger cross section, smaller wall thickness beam will be much lighter and hence have higher natural frequency, but can it be obtained? Indeed there are limited sizes of stock square aluminum tubing, with 8in x 8in x 1/2in wall the largest. One has to go to steel to get larger tube. A 1400 mm long 8in x 8in x 1/4" wall square steel tube would

have a stiffness of 6392 N/mm. What is the “opposite” of a rectilinear tube? A Round tube! There are far more options in round tubing, but what are the implications for bearing mounting and mounting the tube to the rest of the machine? A 10in diameter round tube with 1/2” wall thickness has the same cross sectional area as the 8in x 1/2” wall square tube, but is 20% stiffer in bending and 60% stiffer in torsion. What would you choose?

Back to the router, consider Figure 4 and Figure 8 below. The compliance matrix relates the stiffness of a Coordinate System’s structure from the POI to the center of stiffness (Coordinate System N’s origin). This matrix can be created by the user in the coordinate systems’ worksheets. A 6x6 compliance matrix is needed so the angular deflections of a structure in a coordinate system N are added to the next coordinate system’s (N-1) origin deflections. Then when the *error gains*⁴ for Coordinate system N-1 are applied, they will effectively include the Abbe errors caused by a structural member’s angular deflection causing other elements attached to it to tilt. If a coordinate system is placed at the center of stiffness of bearings that allow motion, the compliance in the direction of motion is considered to be the stiffness of the servo (e.g., ballscrew, coupling, bearings etc.).

At the origin of the coordinate system there will be some sort of attachment to the next Coordinate system’s POI. At each Coordinate system origin there are three resultant forces and moments computed from the forces and moments initially acting on CS_1’s POI plus any additional forces and moments added along the way to a Coordinate System’s POI or origin. If there are forces, such as from center of mass, in-between, they can always be resolved into forces and moments applied to the origin. Hence only three linear and three angular stiffness values are needed to describe the attachment of a coordinate system (just a vector).

This CS origin F=kx Displacements + structural angular displ from next CS		Stiffness of this CS origin wrt its axes		Next CS CS Origin structural angular displ		Next CS CS Origin structural angular displ in this CS		
deltaX	0.000000	KX	0	EpsilonX	0.000000	EpsilonX	0	
deltaY	0.000000	KY	2588000	EpsilonY	0.000000	EpsilonY	0	
deltaZ	0.000000	KZ	2588000	EpsilonZ	0.000000	EpsilonZ	0	
EpsilonX	0.000000	KrotX	6874375000	Unity	1	Unity	1	
EpsilonY	0.000005	KrotY	6604791667					
EpsilonZ	-0.000002	KrotZ	6604791667					
This CS POI F=kx structural displacements		POI displacements = Structure compliance matrix * Force & Moment at POI						POI's F's & M's
deltaX	0.000000	0.00E+00	0.00E+00	0.00E+00	0.00E+00	0.00E+00	0.00E+00	100
deltaY	0.000000	0.00E+00	0.00E+00	0.00E+00	0.00E+00	0.00E+00	0.00E+00	0
deltaZ	0.000000	0.00E+00	0.00E+00	0.00E+00	0.00E+00	0.00E+00	0.00E+00	0
EpsilonX	0.000000	0.00E+00	0.00E+00	0.00E+00	0.00E+00	0.00E+00	0.00E+00	0
EpsilonY	0.000000	0.00E+00	0.00E+00	0.00E+00	0.00E+00	0.00E+00	0.00E+00	30000
EpsilonZ	0.000000	0.00E+00	0.00E+00	0.00E+00	0.00E+00	0.00E+00	0.00E+00	-10000

Figure 9: Image of the attachment point stiffness and compliance matrix for a coordinate system

Since users will tend to forget to enter values, and the default in Excel for an empty cell is “0”, the compliance matrix is used in the error budget spreadsheet. It also makes more

⁴ Some positive angular errors result in negative displacements, thus since random errors have no sign, for all the coordinate systems, the magnitude of the amplification of angular errors must be individually computed for each potential angular error. A table of these amplification factors, or *error gains*, can then be used to compute the Abbe errors attributed to random angular errors about each of the axes of each of the coordinate systems. The error gains for the systematic errors, on the other hand, do have a sign.

sense given that we have forces and want to determine deflections, so $X = C \cdot F$, where $C = 1/k$. Note the matrix will always be symmetric in this analysis. The elements for which 6x6 compliance matrices are needed are shown in Figure 7.

It is desirable to have a worksheet within the error budget spreadsheet for entering the dimensions of members and to calculate the stiffness matrices since the formulas will be similar. Note that when equating the length of a beam by referring to a cell in the worksheet *Axes' CS and Loads* that sometimes the coordinates may be negative, but lengths of beams are always positive, so use the **ABS()** function. Also note when entering formulas for compliances remember to consider the sign. For example, a moment may cause a deflection in a negative direction⁵.

It is helpful to have the formulas for deflection and slope of cantilever and simply supported beams subject to forces and moments as shown in Figure 10. It is very difficult to have a beam with a true zero slope condition at both ends, and it is more conservative to assume a simply supported condition. Note it is important to be careful of the sign of the applied force or moment and the resulting deflections and slopes. These formulas take this into account, such that if a horizontal beam were also attached to the point where the force or moment was applied, the resulting Abbe error would have the proper sign.

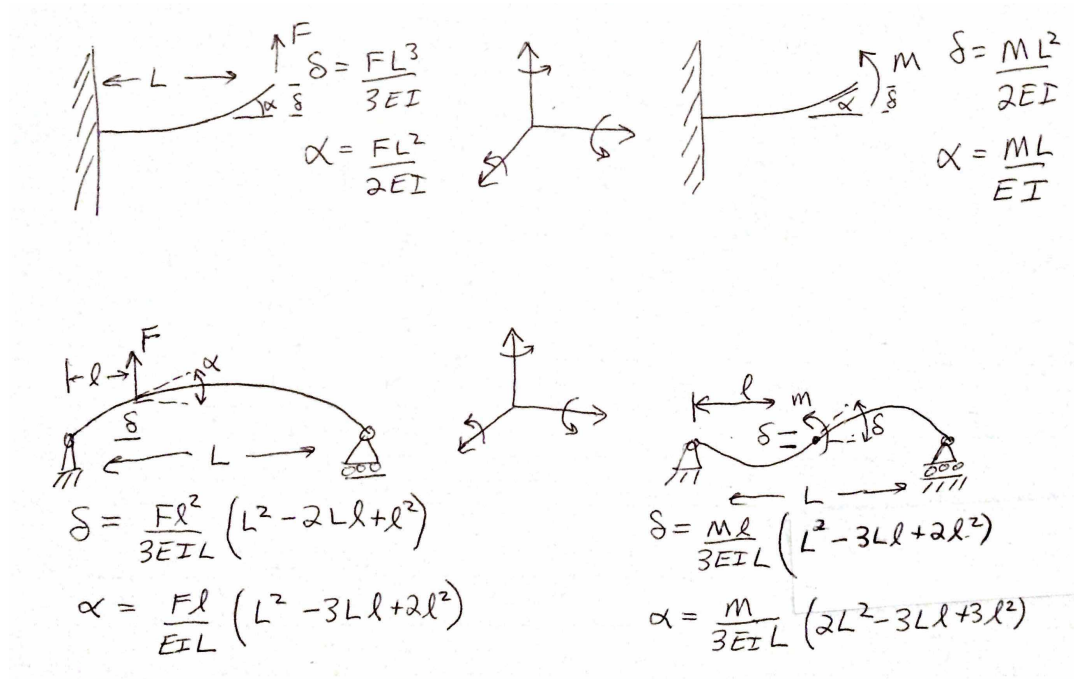

⁵ NOTE Excel has a strange "feature" where entering a formula such as " $-L/(E \cdot I)$ " returns a positive value! Entering " $-1 \cdot L/(E \cdot I)$ " returns a negative value. The same is true when a reference is raised to a power: $-1 \cdot B130^2$ yields $-B130^2$; however, $-B130^2$ yields $B130^2$.

Figure 10: Deflection and slope formulas for common beams used to model machines. Position of the force on a simply supported beam is from left to right. A right hand coordinate system is assumed.

It is very important to create sketches of beams being modeled with their assigned coordinate systems, and compare the orientations to the right hand systems used for shown. A check of the equations shown in Figure 10 corresponds to the shapes shown in the sketches, which can be verified by supporting and loading an object and observing how it deforms. As shown in Figure 11, these values represent the compliances, and it is good to see that they are symmetric: the slope caused by a force has the same sign and value as a deflection caused by the moment.

Simply Supported Beam, Force positive up					
l/L	0	0.25	0.5	0.75	1
deflection	0.000	0.012	0.021	0.012	0.000
Slope	0.000	0.094	0.000	-0.094	0.000
Simply Supported Beam, Moment positive counterclockwise					
l/L	0	0.25	0.5	0.75	1
deflection	0.000	0.094	0.000	-0.094	0.000
slope	0.667	0.479	0.417	0.479	0.667

Figure 11: Normalized results of deflection and slope formulas of Figure 11 applied to common beams used to model machines.

For a servo controlled axes, which controls the position of a CS origin (POA) wrt another coordinate system's POI CS origin (POA@Center of Stiffness), the axial stiffness (compliance) of the system at the Point Of Attachment (POA) will be dominated by the actuator, such as a ballscrew or belt. The compliance of the shaft (or belt) can be computed and then a factor (typically 3 for the attachment (e.g., nut) to the moving member and the support bearings) accounts for the compliance of other elements used to attach it. Figure 12 shows an image from the worksheet *CS_3 Z-Axis*.

servo system (if values needed for this CS)	
Ballscrew	Z axis
Root diameter (mm)	12
Length (mm)	500
Modulus	2.00E+05
shaft stiffness	4.52E+04
factor to derate stiffness of shaft for nut, mo	3

Net stiffness of CS origin (POA@Center of Stiffness) due to attachment points		Servo stiffness (if applicable, else make sure to enter "0")
Linear stiffness		
KX	0.00E+00	0.00E+00
KY	2.59E+06	0.00E+00
KZ	2.60E+06	1.51E+04
Rotation stiffness		
KrotX	6.87E+09	0.00E+00
KrotY	6.60E+09	0.00E+00
KrotZ	6.60E+09	0.00E+00

Figure 12: Results of deflection and slope formulas applied to common beams used to

We are now ready to apply the above to each of the coordinate systems as shown in Figure 7 using the worksheet *bearings, servo, structure*.

CS_1 Tool Holder

Structure compliance (from a coordinate system's POA to its POI)

For the *Tool Holder*, see Figure 5, the compliance is that of the tool which is modeled as a fraction of that of a cylinder to account for the flutes. Figure 13 shows the Tool Holder system compliance calculations done in the worksheet *CS_1 Toolholder*. Note how figures are pasted to help the designer check for the sign of the compliances in accordance with coordinate system placement on the beam element. This should be done for each coordinate system. Note the "Note:" on the last cell. The designer should leave notes on how they modeled the system. Notes can also be attached to individual calculation cells.

Note that the worksheet is made generic, so if certain cells with their entires are not needed, those cells should just be colored blue. No need to delete or clear entries as they may be used in the next round of use of the spreadsheet.

	A	B	C	D	E	F	G	H	I	J	K	L	M
1	CS 1	Tool Holder											
2	Geometric errors at CS origin and location and stiffness of points (or bearings) of attachment between coordinate systems												
3	Error motions of CS Origin along & about its axes. Values read used by "Coordinate Systems" worksheet												
4	Element	Tool	Bearings (if values needed for this CS)		CAREFUL as this compliance matrix is referenced in the worksheet "CSs and Loads"								
5	Structure type	cantilever	Size (e.g., rail width)	25	Tool in toolholder (cantilever beam): X lateral, Y transverse, Z axial								
6	Material	steel tool	Fmax (N)	17346	dx	1.74E-04	0	0	-2.61E-06	0	0	Fx	
7	Young's Modulus (N/mm ²)	2.00E+05	k @ medium preload (N/mm)	647000	dy	0	1.74E-04	0	2.61E-06	0	0	Fy	
8	Poisson ratio	0.29	ball diameter (mm)	3	dz	0	0	2.04E-06	0	0	0	Fz	
9	Shear modulus (N/mm ²)	77519	% deflection max load	0.01	thetaX	0	2.61E-06	0	5.22E-08	0	0	Mx	
10	Beam properties (rectangular tube, or round, else customize)		stiffness est (N/mm)	578200	thetaY	-2.61E-06	0	0	0	5.22E-08	0	My	
11	Position along beam	100	roll width (mm)	25	thetaZ	0	0	0	0	0	6.73E-08	Mz	
12	Length (mm)	100	roll rotary stiffness (Nmm/radian)	101093750									
13	Height (mm), or OD	25	pitch rotary stiffness (Nmm/radian)	33697917									
14	Width (mm), ID or fraction of solid cylinder	50%	yaw rotary stiffness (Nmm/radian)	33697917									
15	Area (mm ²)	245	servo system (if values needed for this CS)										
16	Area (mm ²)	245	Ballscrew										
17	I width dimension of beam (mm ⁴)		Root diameter (mm)	18									
18	I height dimension of beam (mm ⁴)	9587	Length (mm)	2500									
19	I polar (mm ⁴)	19175	Modulus	2.00E+05									
20	I/A stiffness to weight ratio	39	shaft stiffness	2.04E+04									
21	ref, simply supported stiffness about lzz (N/mm)	5752	factor to derate stiffness of shaft for nu	3									
22	Notes: Y axis is + into the page so a + X direction force causes a - rotation about Y axis. Cells not used are colored blue												

Figure 13: Compliance calculations for the Tool Holder coordinate system. Attachment compliance (POA to next CS POI)

The attachment compliance for the tool holder, a tapered collet for example, will be an order of magnitude greater than the stiffness of the tool itself, and even of the spindle shaft.

It is helpful that whenever copying a set of cells, pasting, and then updating the formulas, to change the cell background color as a reminder to make sure to change all the cells! The compliance matrix references the cells to the left, so if additional coordinate systems are to be added for a new machine (or CS), the entire block can just be copied and pasted, and then checked for the orientation of the structure with respect to the coordinate systems and the compliance matrix. As cells are changed, change their background color and thus prevent missing one.

CS_2 Spindle

Structure compliance (from a coordinate system's POA to its POI)

The spindle coordinate system is placed at the center of the spindle shaft between the spindle bearings, as discussed in detail in conjunction with Figure 5 above, and the entries for determining the compliance matrix from the worksheet CS_2 Spindle are shown in Figure 14.

	A	B	C	D	E	F	G	H	I	J	K	L	M
2	Geometric errors at CS origin and location and stiffness of points (or bearings) of attachment between coordinate systems												
3	Error motions of CS Origin along & about its axes. Values read used by "Coordinate Systems" worksheet												
4	Element	spindle shaft	Bearings (if values needed for this CS)		Spindle Shaft Cantilever Beam: X lateral, Y transverse, Z axial position is CS_2 location in CS_3								
5	Structure type	simple supported	Size (e.g., rail width)	75	dx	0.00E+00	0	0	0	0	0	0	Fx
6	Material	steel	Fmax (N)	20000	dy	0	0.00E+00	0	0	0	0	0	Fy
7	Young's Modulus (N/mm^2)	2.00E+05	k @ medium preload (N/mm)	500000	dz	0	0	9.99E-07	0	0	0	0	Fz
8	Poisson ratio	0.29	ball diameter (mm)	3	thetaX	0	0	0	2.86E-09	0	0	0	Mx
9	Shear modulus (N/mm^2)	77519	% deflection max load	0.01	thetaY	0	0	0	0	2.86E-09	0	0	My
10	Beam properties (rectangular tube, or round, else customize)		stiffness est (N/mm)	666667	thetaZ	0	0	0	0	0	5.53E-09	0	Mz
11	Position along beam	200	rail width (mm)	25									
12	Length (mm)	200	roll rotary stiffness (Nmm/radian)	78125000									
13	Height (mm), or OD	50	pitch rotary stiffness (Nmm/radian)	26041667									
14	Width (mm), ID or fraction of solid cylinder	35	yaw rotary stiffness (Nmm/radian)	26041667									
15	wall (mm)		servo system (if values needed for this CS)										
16	Area (mm^2)	1001	Ballscrew										
17	I width dimension of beam (mm^4)	233134	Root diameter (mm)	18									
18	I height dimension of beam (mm^4)	233134	Length (mm)	2500									
19	I polar (mm^4)	466269	Modulus	2.00E+05									
20	I/A stiffness to weight ratio	233	shaft stiffness	2.04E+04									
21	ref, simply supported stiffness about lzz (N/mm)	17485	factor to derate stiffness of shaft for nut, m	3									
22	Notes: Y axis is + into the page so a + X direction force causes a - rotation about Y axis. CS origin is at center of spindle shaft, but to calculate compliance assume full shaft length and POI is at right support												

Figure 14: Compliance calculations for the Tool Holder coordinate system.

Attachment compliance (POA to next CS POI)

Note that the forces applied to the simply supported beam are considered to be at the front spindle bearing and thus they cannot create an angular deflection and the corresponding compliance terms compute to zero, as do the off axis moment effects on displacement.

Attachment compliance (POA to next CS POI)

The stiffness of the POA of CS_2 to the POI on the Z-Axis is assumed to be dominated by the spindle bearings. The attachment points are assumed to be at the equator points of the four bearings

CS_3 Z-Axis

Structure compliance (from a coordinate system's POA to its POI)

The structure between the Z axis POA and its POI (the origin of the Spindle) is dominated by the tube that is the Z-Axis structure itself: The Z-axis bearing blocks are fixed to a plate structure, which also bolts to the Y axis bearing blocks. The Z-Axis profile bearing rails are bolted to the structure, which is modeled as an aluminum square tube. A square tube is considered because the cutting forces can be equal in the X and Y directions and so equal stiffness is needed. Note the length of the structure is tied to

Attachment compliance (POA to next CS POI)

The stiffness of the POA of CS_3 to the POI on the Y-Axis is assumed to be dominated by the Z-Axis' bearing carriages (blocks).

CS_4 Y-Axis

Structure compliance (from a coordinate system's POA to its POI)

The Y-Axis POI is the Z-Axis origin and the two are very close together so there is no appreciable structural compliance between the two: Its just a chunky plate, so the compliances are all set to "0".

Attachment compliance (POA to next CS POI)

The stiffness of the POA of CS_4 to the POI on the Bridge is assumed to be dominated by the Y-Axis' bearing carriages (blocks).

CS_5 Bridge

Structure compliance (from a coordinate system's POA to its POI)

The bridge spans the risers, and to the bridge are attached bearing rails on which the Y axis bearing carriages move. The structural compliance of the bridge structure thus must be calculated. As discussed above, for a closed structural loop machine, an open kinematic model can be used by considering the attachment points for CS_5 to CS_6 to be widely spaced apart (at the top of each riser) and then calculate the angular stiffness of the attachment accordingly. This gives a huge rotational stiffness so the angular deflection will be very small.

The structural compliance is that of a simply supported beam, so when the Y axis is positioned in the middle of the bridge, the angular deflection of the bridge will actually be zero. Near the ends of the bridge, the compliance becomes huge.

Attachment compliance (POA to next CS POI)

The stiffness of the POA of CS_5 to the POI on the X-Axis (the top of the risers) is a bolted connection which if done correctly should be as stiff as if welded. It is modeled as 4 points spaced at the corners of the joint.

CS_6 X-Axis

Structure compliance (from a coordinate system's POA to its POI)

From the plates to which the X-Axis bearing carriages are attached up to the bridge are the risers. The compliance of these structures must be taken together, so for example in the X direction, the compliance of the two risers is one-half of that of a single riser. The torsional compliance about the Z-Axis is the effect of the lateral compliances K of the risers acting as a force couple over the length L of the bridge and is thus $2/KL^2$. The roll compliance about the X-Axis is a function of the compression stiffness of the risers and the bridge length and thus is quite huge.

Just before we come to the end of the structural loop back at the toolpoint, it is important to note that there are essentially two options for placement of the bed's CS origin. The first is to simply locate it in the center of the bed and call that the reference frame origin. Then the entire machine's performance is wrt the reference frame (center of bed).

The second option is to assume that Bed coordinate axis origin is also at the toolpoint, and thus the position of the X-Axis coordinate system with respect to the bed should be such that the origin of the Bed coordinate system is located at the toolpoint. This can be achieved with the product of -1 and the sum of the coordinates along the structural loop chain. This is what will be assumed for this design.

Attachment compliance (POA to next CS POI)

The stiffness of the POA of CS_6 to the POI on the Bed is assumed to be dominated by the X-Axis' bearing carriages (blocks).

CS_7 Bed

Structure compliance (from a coordinate system's POA to its POI)

The structure of the bed is assumed to be a sandwich panel such as plywood bonded to either side of Styrofoam insulation for a home machine or 1/8" aluminum sheets bonded to either side of honeycomb. The bed really thus is more of a plate structure, but for simplicity sake here it is assumed to be a beam of length the same as the bridge, and width ten times its thickness. It ends up being as stiff as the bridge.

The X-Axis servo position thus ends up not being a sensitive parameter, what is more important is the position of the spindle as controlled by the Y axis.

Attachment compliance (POA to next CS POI)

The stiffness of the POA of CS_7 to the POI of the “next” reference frame, given that the next frame is to be at the toolpoint would actually be the attachment of the part being cut to the bed. If properly attached, it should be very much more stiff than the stiffness of the bed itself for example.

Discussion on the layout of the spreadsheet to perform the required analysis

This section is under construction... it is not needed for operation by a user of the spreadsheet, but it is good to discuss the analysis process. It will be written in coming weeks....

Error gains

The following figure illustrates why error gains are needed, and for systematic errors, some of the gains are negative

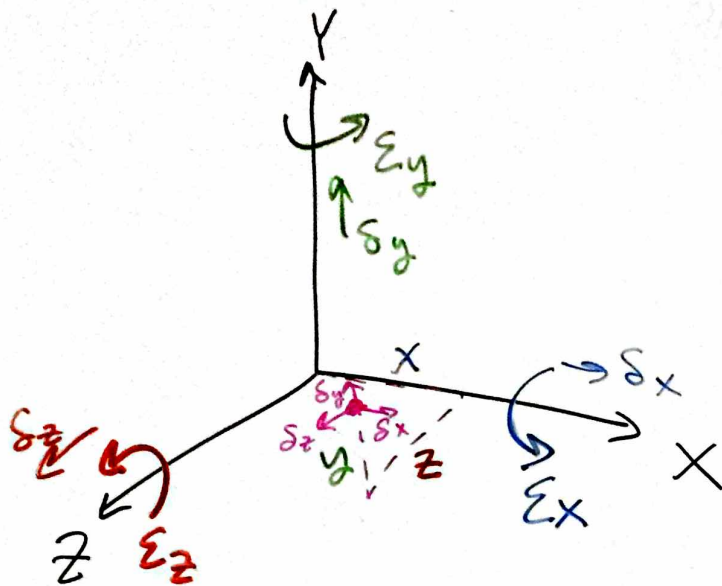

$$\delta_x \approx \epsilon_y z - \epsilon_z y + \delta_x$$

$$\delta_y \approx -\epsilon_x z + \epsilon_z x + \delta_y$$

$$\delta_z \approx \epsilon_x y - \epsilon_y x + \delta_z$$